

# Power safety

## Profitec S

Battery-charging rectifier

The requirements for the secure supply of DC power to critical consumers are largely determined by users in the manufacturing, power supply, telecommunications, chemical and petrochemical industries. These are:

- High operating safety and reliability, even under difficult circumstances over long periods of time
- A monitoring system which detects faults and malfunctions and displays these in plain text
- A completely digital implementation
- High MTBF/Availability
- Convenient display and simple operating characteristics



>>

PERFECT IN FORM AND FUNCTION

**AEG**

# Battery-charging rectifier Profitec S

The Profitec S has been developed and designed to meet just these requirements. This battery-charging rectifier contains thyristors as power- positioning elements and a microcontroller-based control device MCS.

The special features of the Profitec S are:

- Intelligent control and monitoring software
- Transparent operating data through plain-text display
- Uninterruptible transmission of ignition pulses via light-wave conductors
- Redundant supply of microcontroller control unit
- Self monitoring of microcontroller through "watchdog circuit"
- Self-diagnosis with plain-text display
- Consistent galvanic separation between three-phase current input and DC output in accordance with requirements of IEC60364-4-41/VDE 0100 section 410, "Protection for safety- Protection against electric shock" for rated voltages of  $\leq 120$  V
- Consistent compliance with EN 50274/VDE 0660-514 "Protection against electric shock- Protection against unintentional direct contact with hazardous live parts"
- Greater availability through minimization of the number of active and passive components in relation to conventional technology
- Electromagnetic compatibility EMC in accordance with EN 61000-6-2 and 61000-6-4
- Manufactured in accordance with the provisions of ISO 9001
- Complies fully with EC regulations
- Complete natural cooled

## Design of the PROFITEC S:

The main components of the Profitec S are the power unit, the microcontroller-based control unit MCS, the display and operating unit DOU and the power supply interface NS.

### Power unit:

The main elements of the power unit are:

- Input power contractor
- Transformer with separate coils to EN 61558-2-4/VDE 0570-2-4
- Fully controlled thyristor set in 6-pulse circuit
- Smoothing device
- Safety load breaker switch in DC output

### The microcontroller-based control unit MCS:

This is the central control unit in which all the data required for the operation of the Profitec S is generated, processed, monitored and stored. This data is for:

- Regulation and control of the power unit
- Processing of measured values for control, monitoring and display
- Control of thyristors by fibre optic
- Transmission of relevant data e.g. to a control system and/or remote diagnosis system at a central servicing location

### The display and operating unit DOU:

This provides the operator with all the most important information on the status of the unit by means of plain-text display (4-line display

with 40 characters per line) in combination with a three-colour signal-lamp system (surface LEDs), and also allows manual control of the Profitec unit. The display and operating unit has a foil-covered keypad by means of which the rectifier is switched on and off, and the menu level selected.

### The power supply interface NS:

This creates the link between the three-phase power input, external control inputs and the microcontroller-based control unit MCS.

### Options for the PROFITEC S:

- Disconnection switch or circuit breaker in the three-phase power input
- Blocking diode in the DC output for parallel operation
- Additional battery connection with fuse breaker
- Battery-current measurement with display of charging and discharging current
- Monitoring devices (additional boards or components)
  - insulation monitoring
  - battery charging-circuit monitoring system BLÜ4 (parallel operation)
- Counter-EMF Cells (possibly cabinet extension required)
- Charging-voltage adaptation to surrounding temperature
- Interference-suppression grade "B" to EN 55011
- Smoothing for remote-signalling operation (24-volt and 60-volt units)
- Other ratings for the connection voltages (on request)
- Other battery cell quantities
- Other cabinet sizes
- Other paint colours
- Battery charge-current limiting

## DIMENSIONAL DRAWING

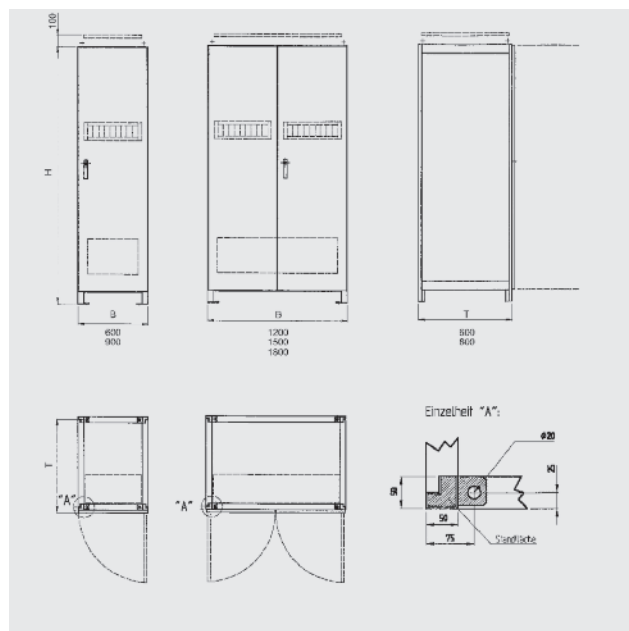

# Profitec S

## Unit Technology

The following events and values are monitored:

Event	Type of fault	Display
Three-phase undervoltage Three-phase overvoltage Mains-supply frequency Rotating field	Self-restoring fault, i.e. the unit is switched off and on again automatically after removal of fault	Red LED flashes Status signal fault and fault alarm in display
DC overvoltage (immediate or delayed) Ripple monitoring Short-circuit monitoring Synchronization Thyristor set Deviation from characteristic Break in cable <ul style="list-style-type: none"> <li>• Actual current value</li> <li>• Actual voltage value</li> <li>• MCS supply</li> <li>• Watch-dog</li> </ul>	Permanent switch-off. The unit must be switched on again manually after removal of fault	Red LED flashes Status signal fault and fault alarm in display
DC undervoltage Charge and equalizing charge through external contact blocked	Signal only. No switch-off	Green LED lights up, yellow LED flashes Status signal fault and fault alarm in display
Disruption of data line between MCS -DOU	Signal only. No switch-off	Fault alarm in display

## Monitoring and signalling of faults:

An intelligent monitoring concept includes virtually all types of fault in the mains power supply, the Profitec S and the battery circuit.

A distinction is made between:

- Self-restoring faults
- Faults causing permanent switch-off
- Faults signalized but without switch-off

## Remote signalization:

All the faults recorded are available for remote signalization:

- Collectively as central signal via a potential-free changeover contact wired to terminals.
- As individual signal via RS485 serial interface



Display and operating unit DOU for Profitec S

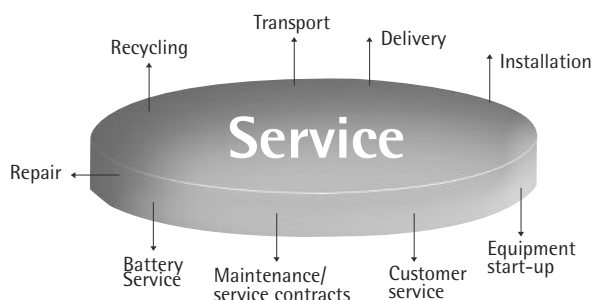

## On service and quality:

For decades, rectifiers made by AEG Power Solutions have been a byword for:

- Well applied technology
- Excellent value for sums invested
- Outstanding quality

Experience, modern production equipment and continuous uncompromising quality assurance give our customers the assurance that products made by AEG Power Solutions are perfect in material and workmanship and will give long periods of service. Our commitment to solving the customer's technical problems is as self-evident as innovative technologies which are fully in harmony with the environment.

Our guiding principle is therefore permanent availability in the common search for the perfect solution. Another essential principle of our company is rapid and efficient service work, and, if necessary, the dispatch of one of our specialist engineers to the customer's site. With more than 50 sales and service branches we are always close to the customer.

The AEG Power Solutions consultant engineers are abreast of the latest technical developments, highly motivated and are pleased to discuss the customer's technical projects in detail. The decision to purchase a battery-charging rectifier manufactured by AEG Power Solutions therefore means reliability in function and safety of investment.

# Operating modes

For a secure DC supply, a number of very different operating modes are required. The possibilities offered by the Profitec S are virtually unlimited. The Profitec S can charge sealed or vented lead acid batteries or NiCad batteries. The basic version allows the use of the following operating modes, all of which can be selected manually.

## Maintenance charge:

The maintenance charge uses an IU characteristic line with a set maintenance-charge voltage of 2.23 volts per cell for lead batteries and 1.4 volts per cell for NiCd batteries. This charging stage allows both maintenance of the charge as well as recharging of a lead battery.

## Charging\*:

Charging can be carried out at an increased voltage using an IU characteristic (manual initiation and end of charge), e.g. 2.4 volts per cell with lead batteries including an automatic switch-back to maintenance-charge voltage after a period of 8 hours. This mode can be locked by means of an external potential-free contact (optional).

## Equalizing charge\*:

The equalizing charge uses an IUoU characteristic. This means that the output voltage of the Profitec S rises (for lead batteries up to 2.65 V per cell and for NiCd batteries up to 1.8 V per cell) and the unit current is limited depending on the rated capacity of the battery. By means of a safety switch-back, the equalizing charge ends automatically after 8 hours at the latest and switches back to maintenance-charge voltage.

\*Please note: As the DC loads are not designed for this increased voltage, please disconnect all loads before each equalizing charge. To ensure the operating reliability, this mode can be locked by an external potential-free contact (e.g. from the infeed switch of the downstream DC distribution).

## Commissioning charge\*:

To charge a battery for the first time, this mode makes use of a higher voltage in accordance with variable characteristics which can be selected as required.

## NEA operation:

Reduction of the output voltage while the Profitec S is supplied temporarily by an emergency-power unit (NEA). This ensures that the charging rectifier does not have to supply current for either charging or maintenance-charging of the battery, thereby reducing the load on the emergency-power unit.

## Diode test:

This is intended for blocking diodes in the rectifier output and/or DC distribution by reducing the output voltage (manual initiation and ending) with automatic safety switch-back to maintenance-charge voltage after expiry of 8 hours.

## Options:

### Automatic charging

Here, the voltage is increased after every discharge (recharge stage), (e.g. after a power failure) with automatic switch-back to maintenance-charge voltage after expiry of the set period of time or 8 hours at the most. Charging is done with the IU characteristic.

### Automatic charging

As described above, but with additional time-dependant interval charging for NiCd batteries.

Interval time: min. two weeks  
max. four weeks

Charge time: min. 30 minutes  
max. 160 hours



# Method of operation

## Block diagram A:

Profitec S with W3C thyristor set

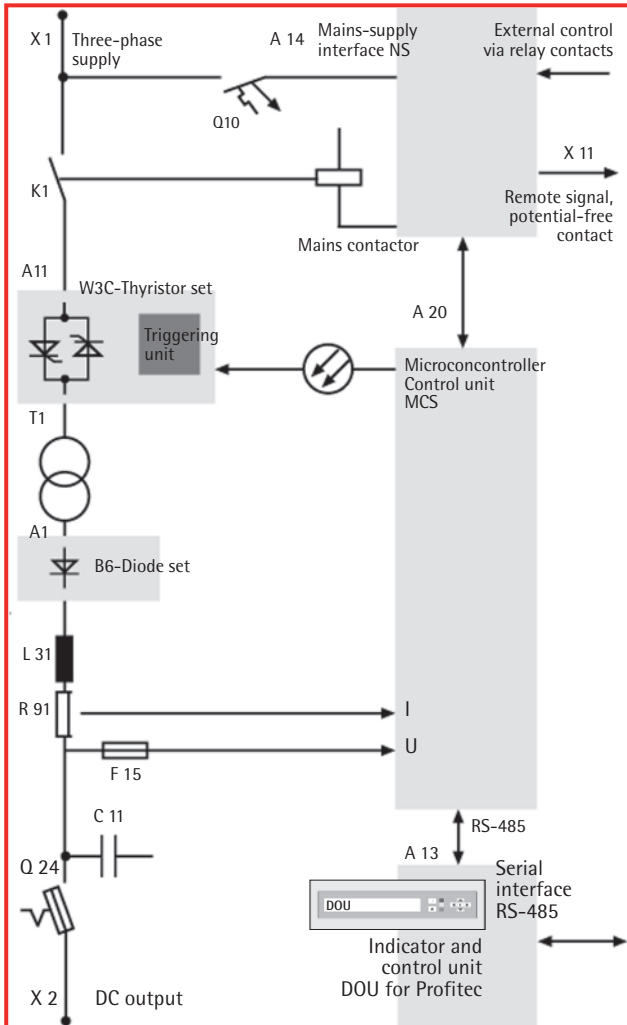

## Block diagram B:

Profitec S with B6C thyristor set

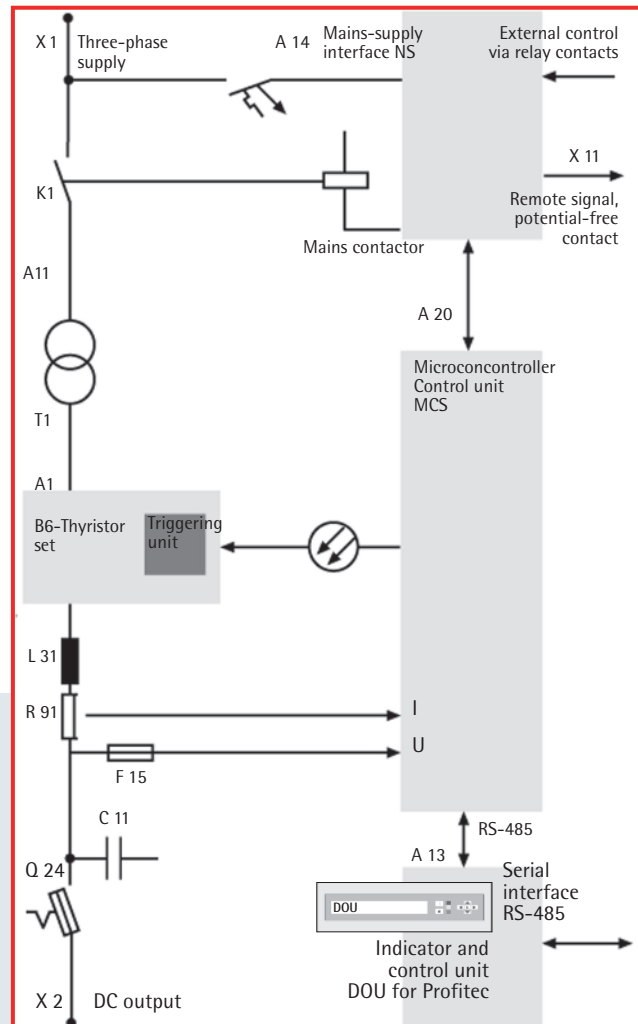

# Technical Data

Rectifier type	D 400 G.../...BWrug Vp		
Connected voltage	3 x 400V $\pm 10\%$ /50 Hz with N conductor		
Type series	24V/60V/110V/220V		
Overall efficiency	24V unit: approx. 85%		
	60V unit: approx. 88%		
	110V unit: approx. 91%		
	220V unit: approx. 93%		
Power factor $\cos \varphi$	24V unit: approx. 0.72		
	60V unit: approx. 0.72		
	110V unit: approx. 0.78		
	220V unit: approx. 0.78		
Type of battery and number of cells	24V unit:	11-13	Cells Pb or
		18-20	Cells NiCd
	60V unit:	27-30	Cells Pb or
		43-46	Cells NiCd
	110V unit:	50-55	Cells Pb or
		80-85	Cells NiCd
220V unit:	100-110	Cells Pb or	
	160-170	Cells NiCd	
Characteristic line	IU to DIN 41 773		
Thyristor circuit	6-pulse circuit		
	24V unit:	W3C-Thyristor set	
	60V unit:	W3C-Thyristor set	
	110V unit:	W3C-Thyristor set	
		from 400 A, B6C-Thyristor set	
220V unit:	B6C-Thyristor set		
Voltage ripple	(Block diagram - see page 5) 5% SS without parallel Battery		
Spurious emissions	to EN 61000-6-4		
	interference to EN 55011 class "A"		
Noise Immunity	to EN 61000-6-2		
Serial interface	RS 485		
Design	Steel cabinet with front door.		
	Double door from cabinet width from 1200 mm		
	DOU integrated in (right-hand) door		
	3-phase connections in cabinet at bottom right		
	DC connections in cabinet at bottom left		
Cabinet Protection	IP 20 (standard) to EN 60529/IEC 529		
Ambient temperature	0° C to + 40° C		
Noise level	$\leq 65$ dbA		
Cooling system	Air natural cooling		
Colour	RAL 7035, Structured (Powder coating)		

## Technical Data

RATED CURRENT (A)	TYPE	3-PHASE POWER INPUT		LOSSES (kW)	WEIGHT (KG)	DIMENSIONS (MM)			
		CURRENT (A)	POWER (kVA)			W (MM)	H (MM)	D (MM)	
<b>RATED VOLTAGE 220 V</b>									
40	D400G212/40 BWrug-Vp	20	13.8	0.7	280	600	1800	600	
63	D400G212/63 BWrug-Vp	31	21.4	1.1	360	600	1800	600	
100	D400G212/100 BWrug-Vp	49	33.8	1.8	450	900	1800	600	
125	D400G212/125 BWrug-Vp	61	42.1	2.3	650	900	1800	600	
160	D400G212/160 BWrug-Vp	78	53.8	2.9	750	900	1800	800	
200	D400G212/200 BWrug-Vp	98	67.6	3.6	880	900	1800	800	
315	D400G212/315 BWrug-Vp	155	107	5.7	1000	1200	1800	800	
400	D400G212/400 BWrug-Vp	195	135	7.2	1100	1200	1800	800	
500	D400G212/500 BWrug-Vp	245	169	9.0	1250	1200	1800	800	
630	D400G212/630 BWrug-Vp	308	213	11.4	1500	1200	1800	800	
800	D400G212/800 BWrug-Vp	390	269	14.5	1600	1200	2200	800	
1000	D400G212/1000 BWrug-Vp	488	337	18.0	2400	2x1200	2200	800	
1250	D400G212/1250 BWrug-Vp	610	420	22.6	2600	2x1200	2200	800	

Different input voltages and mains frequency of 60 Hz on request.

RATED CURRENT (A)	TYPE	3-PHASE POWER INPUT		LOSSES (kW)	WEIGHT (KG)	DIMENSIONS		
		CURRENT (A)	POWER (kVA)			W (MM)	H (MM)	D (MM)

#### RATED VOLTAGE 24 V

100	D400G24/100 BWrug-Vp	6.6	4.6	0.5	150	600	1800	600
160	D400G24/160 BWrug-Vp	10.5	7.2	0.8	220	600	1800	600
200	D400G24/200 BWrug-Vp	13	9.0	1.0	280	600	1800	600
315	D400G24/315 BWrug-Vp	21	14.5	1.6	410	600	1800	600
400	D400G24/400 BWrug-Vp	27	18.6	2.0	500	900	1800	600
500	D400G24/500 BWrug-Vp	33	22.8	2.5	620	900	1800	800
630	D400G24/630 BWrug-Vp	42	29.0	3.2	700	900	1800	800
800	D400G24/800 BWrug-Vp	52	36	3.8	800	900	2200	800
1000	D400G24/1000 BWrug-Vp	65	45	4.7	1000	900	2200	800
1250	D400G24/1250 BWrug-Vp	80	55	5.9	1200	900	2200	800
1600	D400G24/1600 BWrug-Vp	104	72	7.6	1500	1200	2200	800
2000	D400G24/2000 BWrug-Vp	130	90	9.5	1700	1200	2200	800
2500	D400G24/2500 BWrug-Vp	163	112	11.9	2000	1800	2200	800

#### RATED VOLTAGE 60 V

63	D400G60/ 63 BWrug-Vp	8.8	6.1	0.6	175	600	1800	600
125	D400G60/125 BWrug-Vp	17	11.7	1.2	300	600	1800	600
160	D400G60/160 BWrug-Vp	22	15.2	1.6	400	600	1800	600
200	D400G60/200 BWrug-Vp	27.5	19.0	1.9	450	600	1800	600
315	D400G60/315 BWrug-Vp	43	29.7	3.0	600	900	1800	600
400	D400G60/400 BWrug-Vp	55	38.0	3.8	800	900	1800	800
500	D400G60/500 BWrug-Vp	68	46.9	4.8	950	900	1800	800
630	D400G60/630 BWrug-Vp	87	60.0	6.0	1100	1200	1800	800

#### RATED VOLTAGE 110 V

63	D400G106/ 63 BWrug-Vp	15.7	10.8	0.8	250	600	1800	600
100	D400G106/100 BWrug-Vp	25	17.3	1.3	400	600	1800	600
125	D400G106/125 BWrug-Vp	31	21.4	1.6	500	600	1800	600
200	D400G106/200 BWrug-Vp	50	34.5	2.5	600	900	1800	600
315	D400G106/315 BWrug-Vp	77	53.1	4.0	930	900	1800	800
400	D400G106/400 BWrug-Vp	100	69.0	4.9	1100	900	1800	800
500	D400G106/500 BWrug-Vp	123	84.9	6.2	1250	1200	2200	800
630	D400G106/630 BWrug-Vp	155	107	7.9	1400	1200	2200	800